

# SD012 Double Oven

Satin Stainless Steel Code 9911

## Smeg Thermosealed, Fan Forced, Multi Function, Fully Automatic



COLOUR	Satin Stainless Steel
SIZE	890mmH x 596mmW x 566mmD
CAPACITY	Main 66.5 litre gross 56.1 litre nett Auxiliary 44.8 litre gross 38.9 litre nett
INSTALLATION	Wall column
THERMOSTAT	Variable 0° -250° Celsius both ovens
MULTIFUNCTION	Main :7 cooking functions plus defrost Auxiliary :4 cooking functions
FULLY AUTOMATIC	Digital logic analogue clock, time of day, fully auto and semi auto. cooking, minute minder and manual override
CAVITY COOLING	Independent self cooling carcass fan, Triple glazed doors with forced air cooling
FURNITURE	2 x baking/grill trays with grids, 2 x biscuit trays, 2 x chrome wire shelves Removable roof liner (both ovens) 2 x safety handles
CATALYTIC LINERS	Fitted set of three (3) to both ovens, removable
SAFETY	Thermal overload protection. Safety notched furniture.

### MULTIFUNCTION

Main Oven



Auxiliary Oven



### SMEG THERMOSEAL

Unique to Smeg is the fully sealed, non venting ovens. This sealing ensures larger capacity loading, lower temperatures and faster cooking.

### CLEANER COOKING

Since the oven cavities are denied a vented air supply there is reduced splatter and oxidising ('burning-on') of food particles and fluids onto interior surfaces and oven furniture.

### SELF SUFFICIENCY

The thermoseal ensures cooking does not require the addition of fluids (fats, oils) to maintain a moist cooking environment. Nor do the ovens require attention, that is, turning, basting or repositioning while fan grilling, roasting or baking.

### FULLY AUTOMATIC

The main oven of the SD012 oven can be pre programmed to start and finish cooking. It is as well, semi automatic in that the cooking is started manually and then programmed to finish at a set time. There is also the 'Minute minder', variable up to 60 minutes. This simply counts down to an audible signal with volume variability, a perfect reminder call to return to the oven for, perhaps, a cooking adjustment. These timing applications, help ensure perfect cooking results and, importantly, peace of mind.

### REMOVABLE ROOF

Also uniquely Smeg is the removable vitreously enameled roof over the grill element in both ovens. Historically this is the most inaccessible and difficult area of an oven to clean. Now, simply slide this liner out for easy wiping over or dishwasher loading.

### CATALYTIC WALL LINERS

These panels are standard fitted accessories to the both ovens. The set of three is fitted over the side and rear walls. They absorb airborne grease/oil/food particles throughout the cooking process to eventually carbonise this organic waste. Maintenance is then made even easier.

### SAFETY COOLING

An independent fan sources air from the kitchen and passes this air through the control panel and then around the carcass of the ovens exiting at the lower front of the oven back into the kitchen. The triple glazed door, in unison with the cavity cooling system ensures all external surfaces are safe to touch.

### TRIPLE GLASS DOOR

Three layers of thermo reflective glass ensure the heat generated within the oven cavity is contained and efficiently used. Radiant heat to the outside, that is, the kitchen is kept to a minimum. The triple glazing also ensures safe to touch surfaces.

### FOCED AIR COOLING

Recirculating air from the cavity cooling system is mixed with fresh air and convected upwards between the doors' glass panes. This process effectively helps the cooling of the ovens' fascia, door surfaces handles and control dials.

### WARRANTY

Two years on parts and labour.

# SD012 Double Oven

Satin Stainless Steel Code 9911

**Smeg Thermosealed, Fan Forced, Multi Function, Fully Automatic**

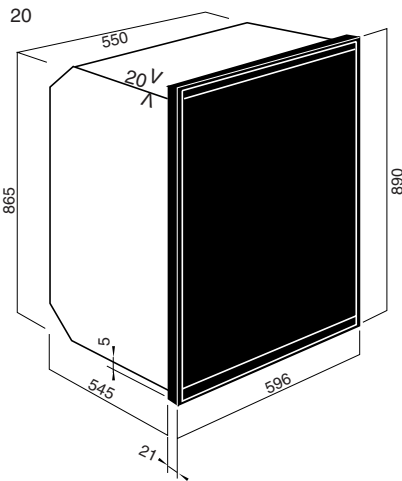

SMEG DOUBLE OVEN

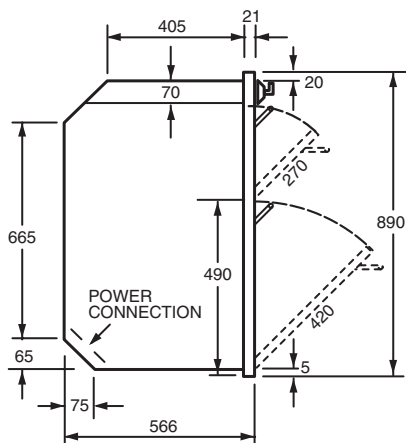

SIDE ELEVATION

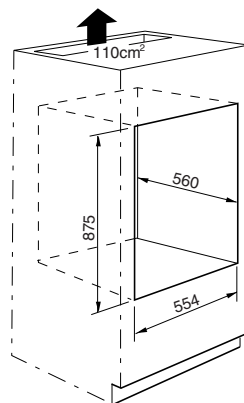

PROUD MOUNT CUTOUT

(For flush mounting add max. 4mm to height and width for cabinet dimensions)

Height 890mm  
Width 596mm  
Depth 566mm

**CUTOUT Proud Mounted**

Height 875mm  
Width 554mm  
Depth 560mm  
Packaged Dimensions 100Hmm x 700mm x 650mm  
Gross Volume 0.455m<sup>3</sup>  
Nett Weight 56kg  
Gross Weight 63kg  
Main Oven Capacity 340mmH x 460mmW x 425mmD = 66.47 litre

Main Oven Cooking Capacity 305mmH x 460mmW x 400mmD = 56.12 litre

Auxiliary Oven Capacity 232mmH x 460W x 420mmD = 44.82 litre

Auxiliary Oven Cooking Capacity 204mmH x 460W x 415mmD = 38.94 litre

Maximum Current 24.69 amp  
Electricity Supply 240 volt 50Hz  
Electrical Connection Hard wired, single phase

**SUPPLIED**

Screws for mounting, instructions for installation, operation and maintenance, cookbook, 2 x baking/grill trays with grid, 2 x chrome wire shelves, 2 x biscuit tray, 2 x safety handles, Removable roof liner (both ovens), Catalytic liners (3) fitted to both ovens.

## Smeg SD012 Double Oven

ELEMENT MAIN OVEN	ROOF		FLOOR	REAR WALL	REAR WALL FAN	COOLING FAN	LIGHT	MAX WATT	CURRENT AMP
	INNER	OUTER							
WATTAGE	1800	1100	1300	2200	45	24	15		
FAN FORCED	•	•	•	•	•	•	•	2284	9.52
SUPER COOK	•	•	•	•	•	•	•	2944	12.3
FAN ASSISTED	•	•	•	•	•	•	•	2484	10.35
FAN GRILL	•	•	•	•	•	•	•	2484	12.44
STATIC GRILL	•	•	•	•	•	•	•	2939	12.25
STATIC CONVECTION	•	•	•	•	•	•	•	2439	10.17
BASE COOKING	•	•	•	•	•	•	•	1339	5.58
<b>AUXILIARY OVEN</b>									
STATIC CONVECTION	•	•	•	•	•	•	•	2439	10.17
BASE COOKING	•	•	•	•	•	•	•	1339	5.58
STATIC GRILL	•	•	•	•	•	•	•	2939	12.25
HALF STATIC GRILL	•	•	•	•	•	•	•	1839	7.67

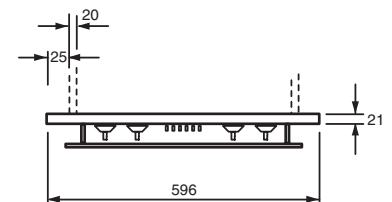

PLAN (FRONT)

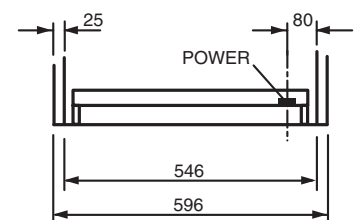

REAR (LOWER) ELEVATION POWER

Warning: Technical specifications and product sizes can be varied by the manufacturer - without notice. Cut outs for appliances should only be by physical product measurements. The above information is indicative only.